

The prototype of the AMS02-RICH: results of test beam

By the AMS02-RICH collaboration

The RICH

The Ring Imaging Cherenkov (RICH) detector will provide AMS with a measurement of 0.1% resolution for particles above threshold. In addition to this, the wide dynamical range of the RICH PMTs + electronics will allow charge measurement up to Z=26 (Iron).

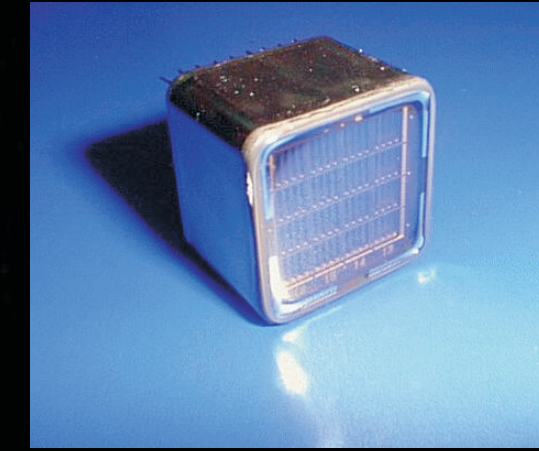
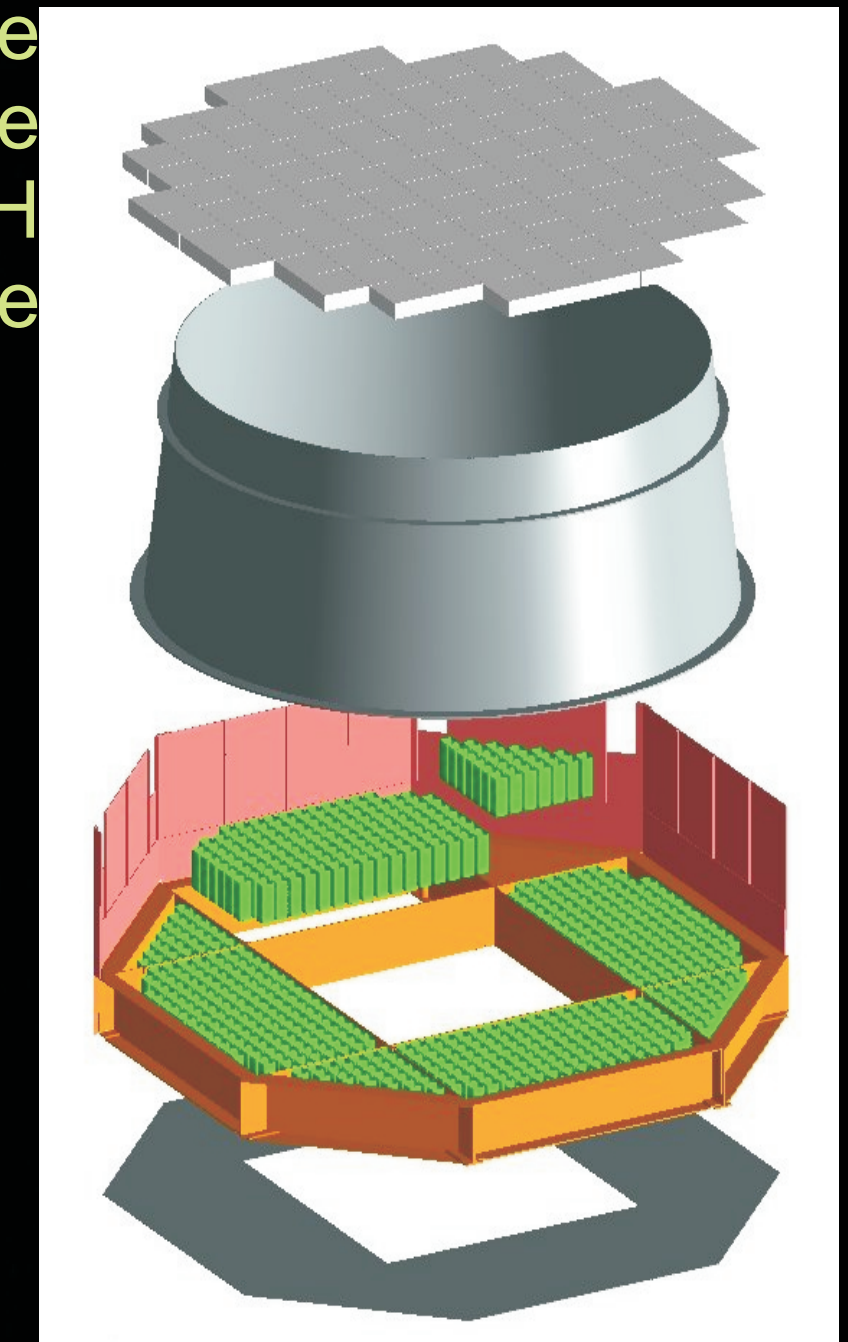

A Hamamatsu PMT.



The RICH reflector

AMS-02 detector

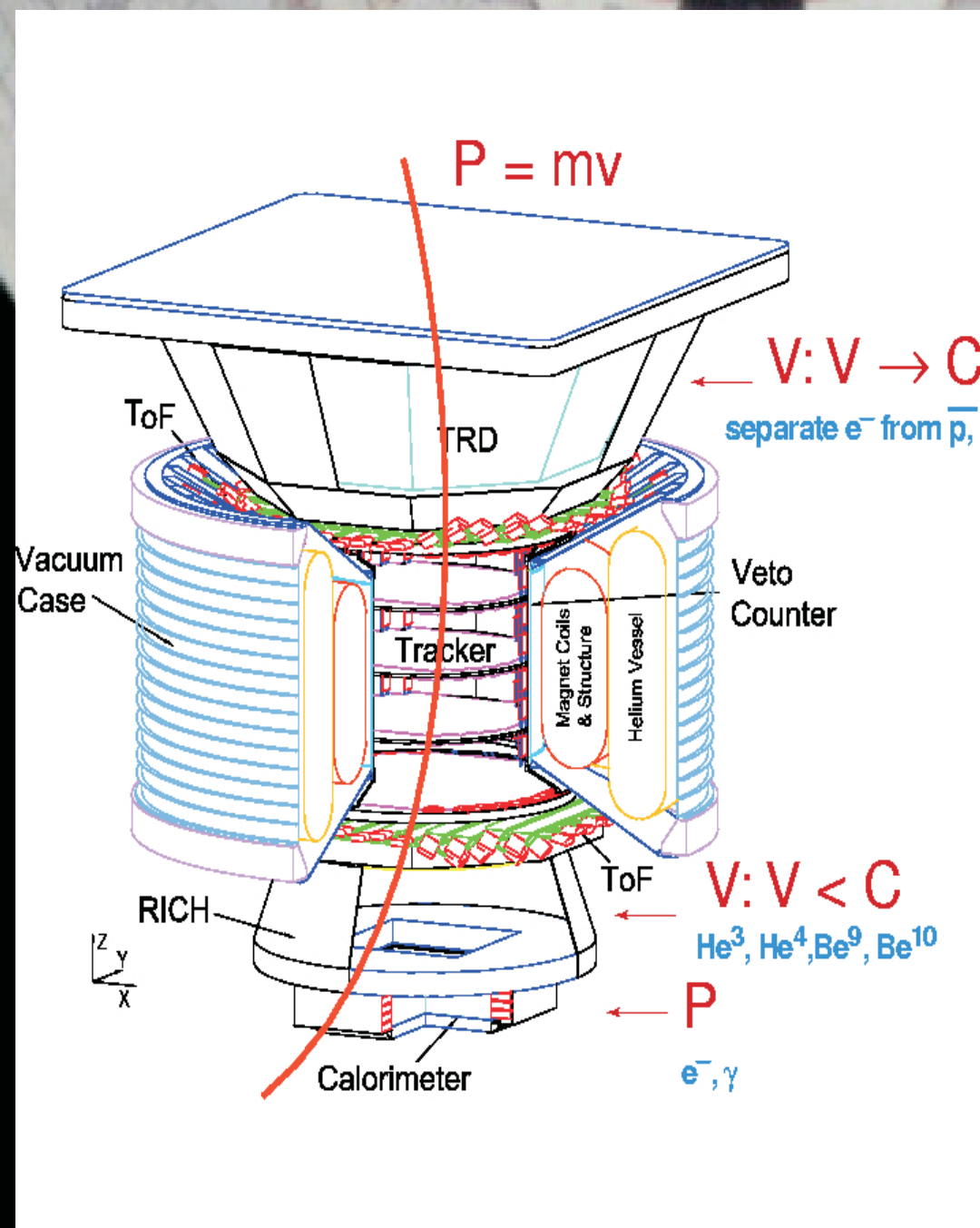

The Antimatter Magnetic Spectrometer (AMS) is a particle physics experiment designed to operate in space. Primary objectives of the experiment are the search for antimatter and dark matter components in primary cosmic rays (CR). Moreover, thanks to its large acceptance and the high statistics expected during a three year mission on the ISS, AMS will measure primary CR spectra with very high precision. The main components of AMS-02 are: a superconducting magnet of 1.2 m inner diameter, bending power 0.86 Tm^2 , a time of flight system, to provide the trigger, and charge measurement, a silicon tracker, to Perform high precision track reconstruction. A transition radiation detector and an electromagnetic calorimeter provide electron/hadron separation and give ray energy and direction measurement. A RICH detector measures with high resolution and charge up to Iron.

The RICH prototype

The feasibility of the RICH detector has been checked with a PROTOTYPE, consisting of a block of radiator and an array of 96 PMTs arranged in a rectangular matrix, all enclosed in a volume with completely absorbent walls. The PMTs and the FE electronics are the same of the final RICH design. Many types of aerogel (Agl) with different optical properties have been tested, in order to choose the more suitable for the final RICH.

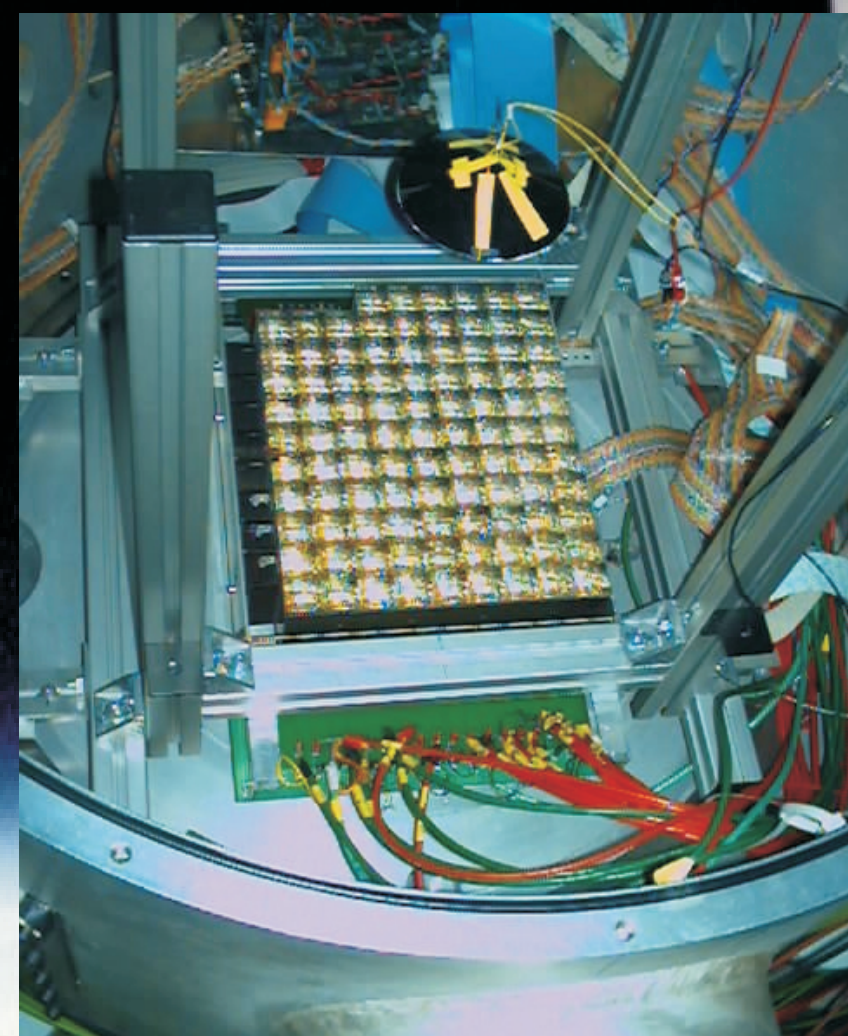

The prototype has been tested with cosmic muons at sea level at ISN of Grenoble and at SPS of CERN with beams of particles of different charge and momentum

View of the detection plane of RICH prototype

The RICH consists of a 3 cm layer of radiator, an expansion volume of 47 cm height where photons propagate in vacuum and a photodetection plane, made up by an array of 680 PMTs. The detector is sealed by a conical mirror of carbon fiber with the shape of a truncated cone. The high precision beta measurement combined with the tracker momentum determination (1.5% for p at 10 GeV) will allow Be isotope separation . up to 10 GeV/n.

Proton ring: Z=1

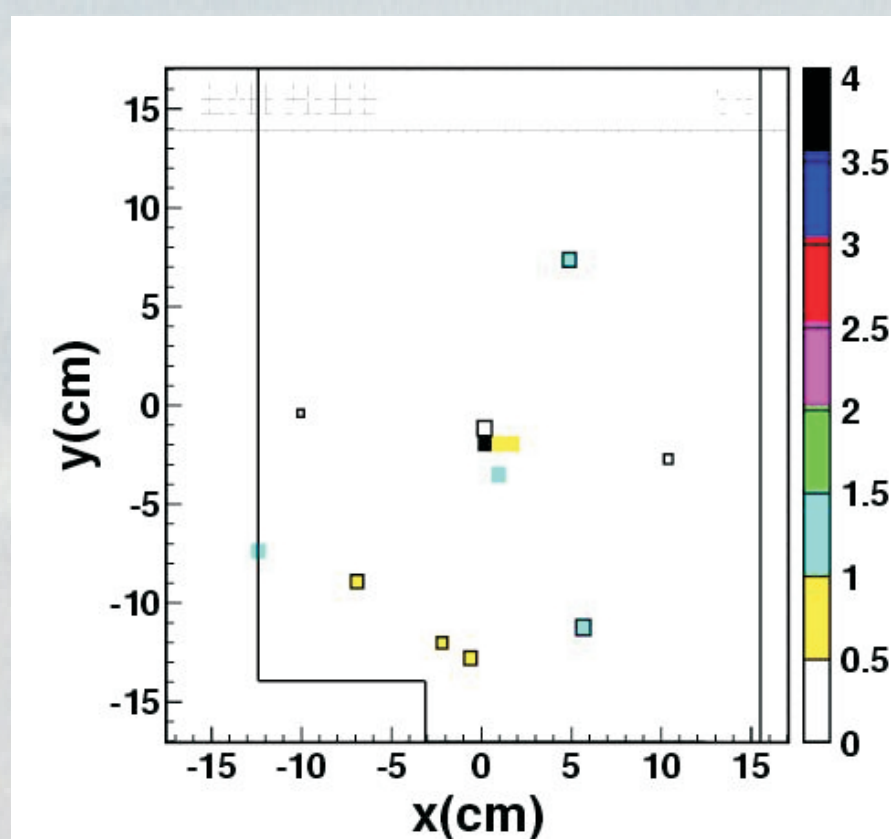

Iron ring: Z=26

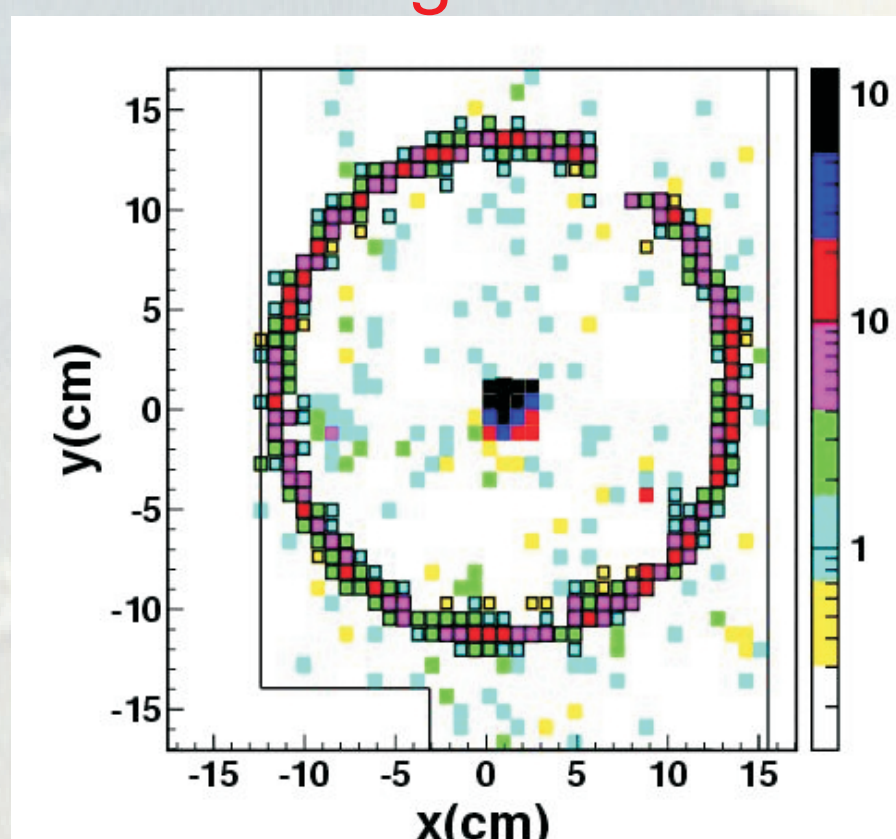

Test beam results

The events analysed have been selected asking for a good reconstructed track and a ring image with at least 3 hits.

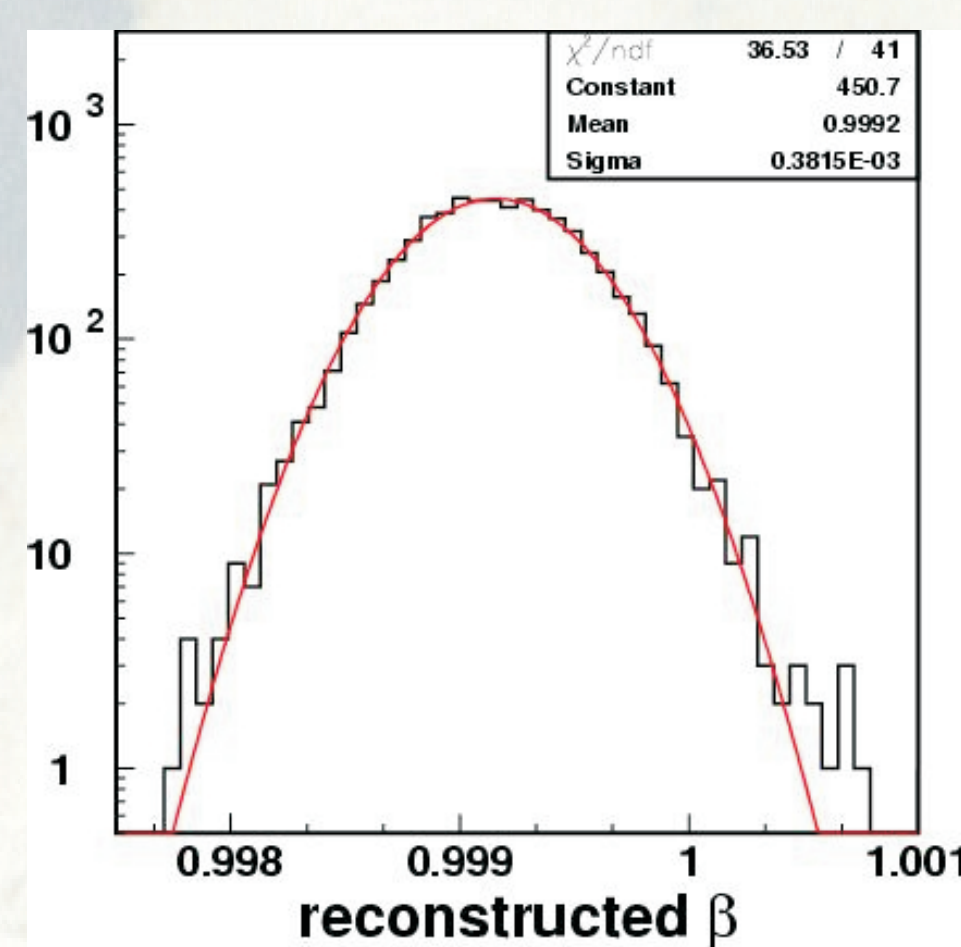

The reconstructed for radiator Agl of index 1.03: a gaussian distribution with

He at p=40 GeV

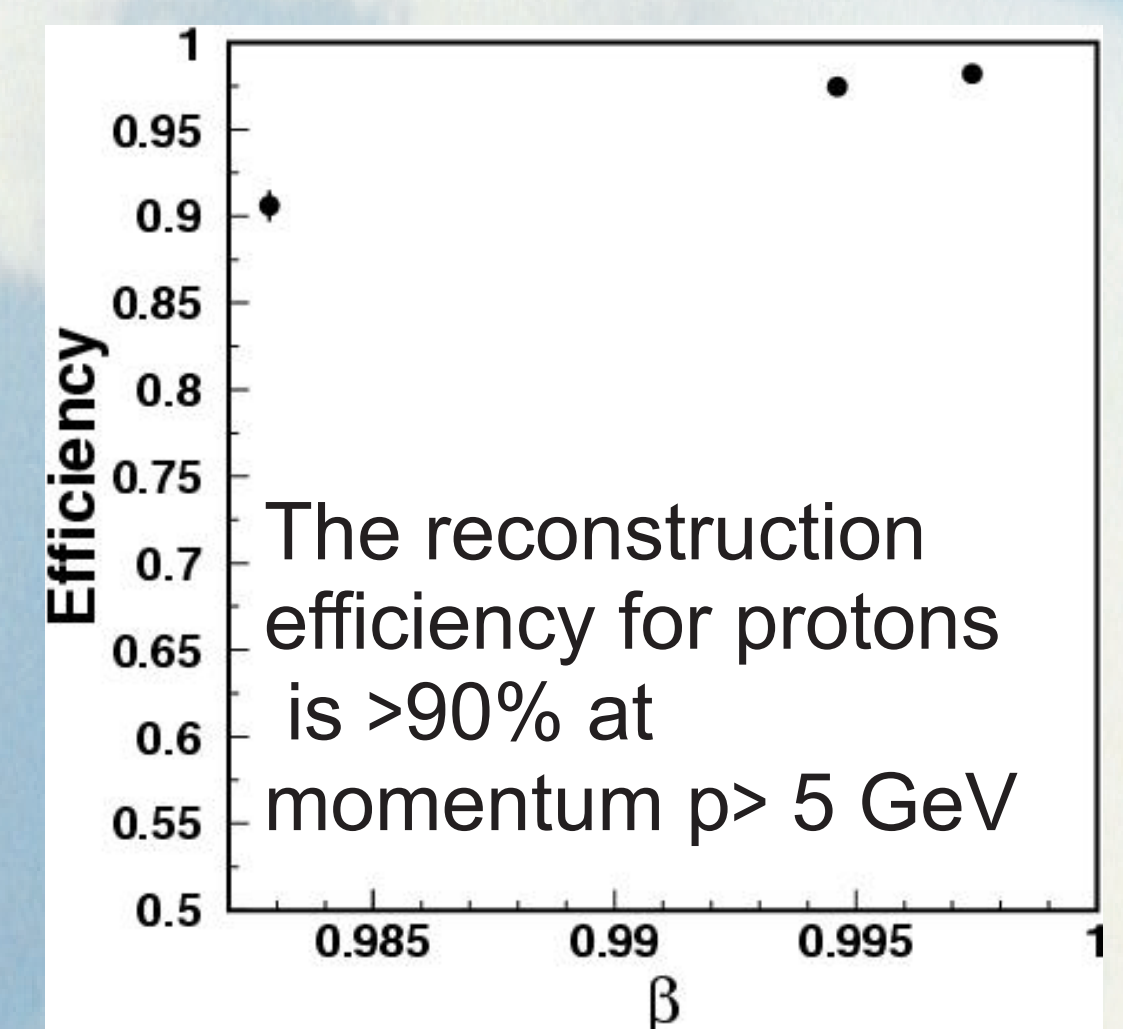

First, from the ring image reconstruction the Cherenkov angle is computed and thus the particle beta (β):

$$\cos(\theta) = 1/(n \times \beta)$$

Counting the number of photoelectrons of the hits in the ring, the particle charge is determined:

$$Z = p.e.$$

The resolution improves with Z until the expected saturation limit is reached. The evolution is independent of the reconstruction algorithm.

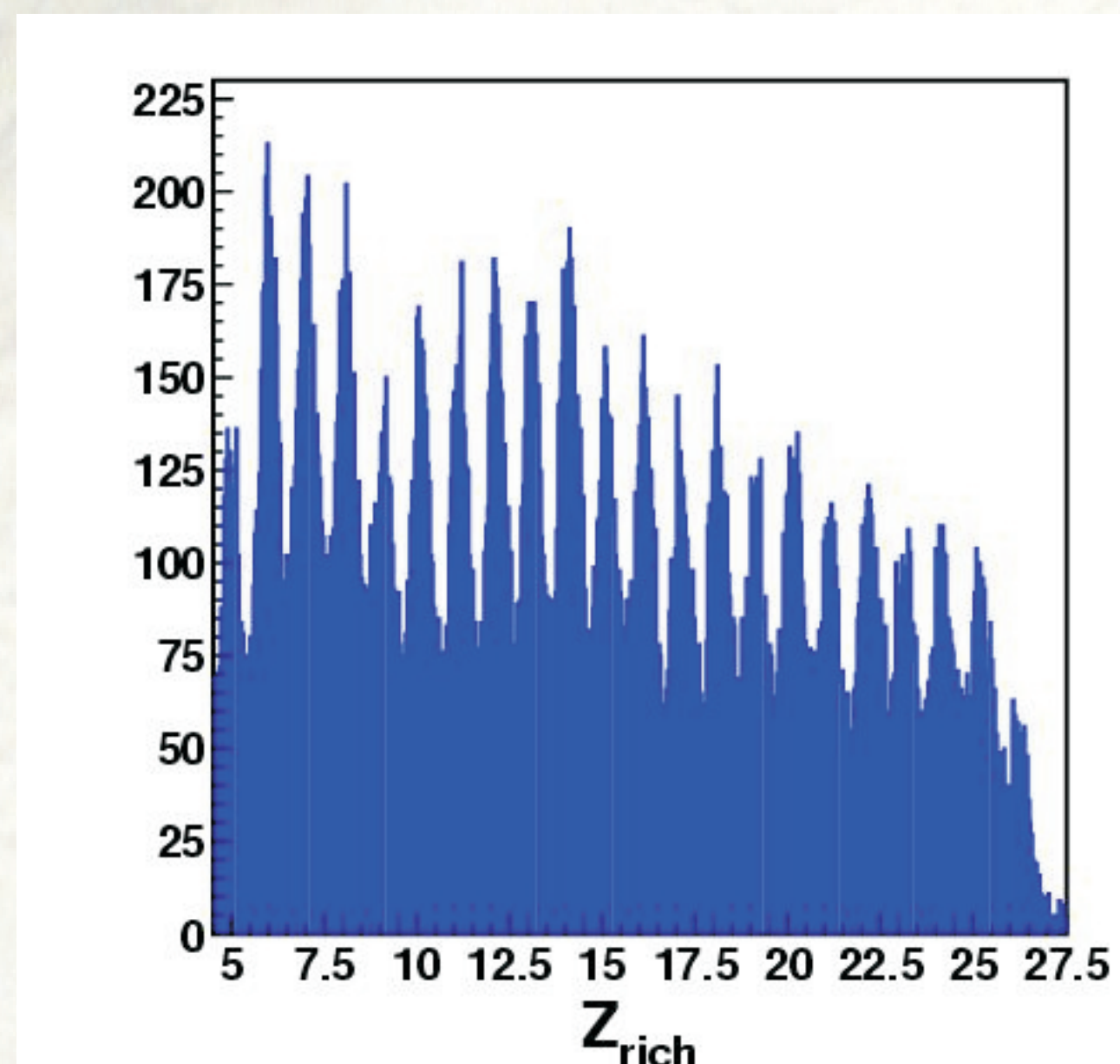
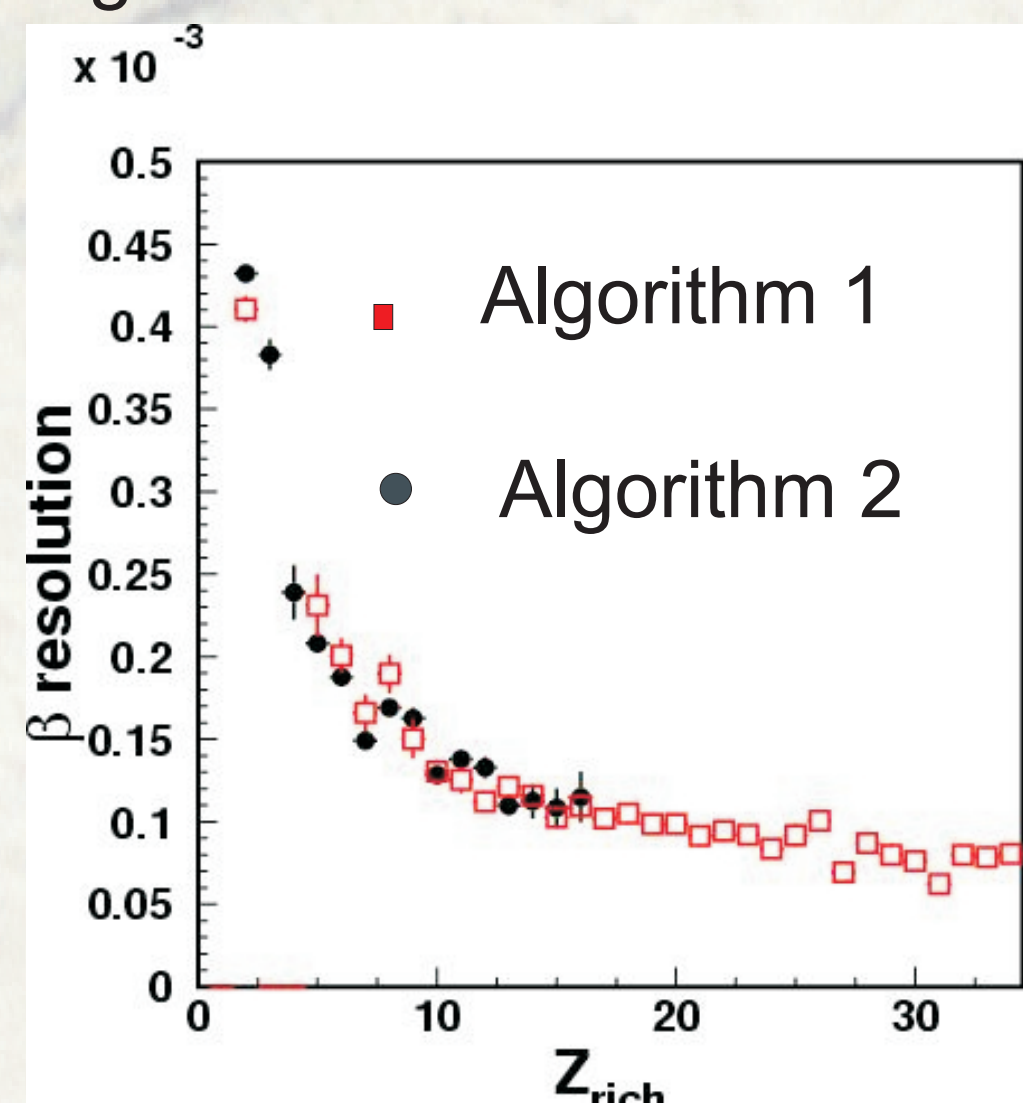

Charge spectrum for a run with Agl of index 1.04

Charge distribution for a sample of He with a Gaussian fit: data are well reproduced by the MC simulation

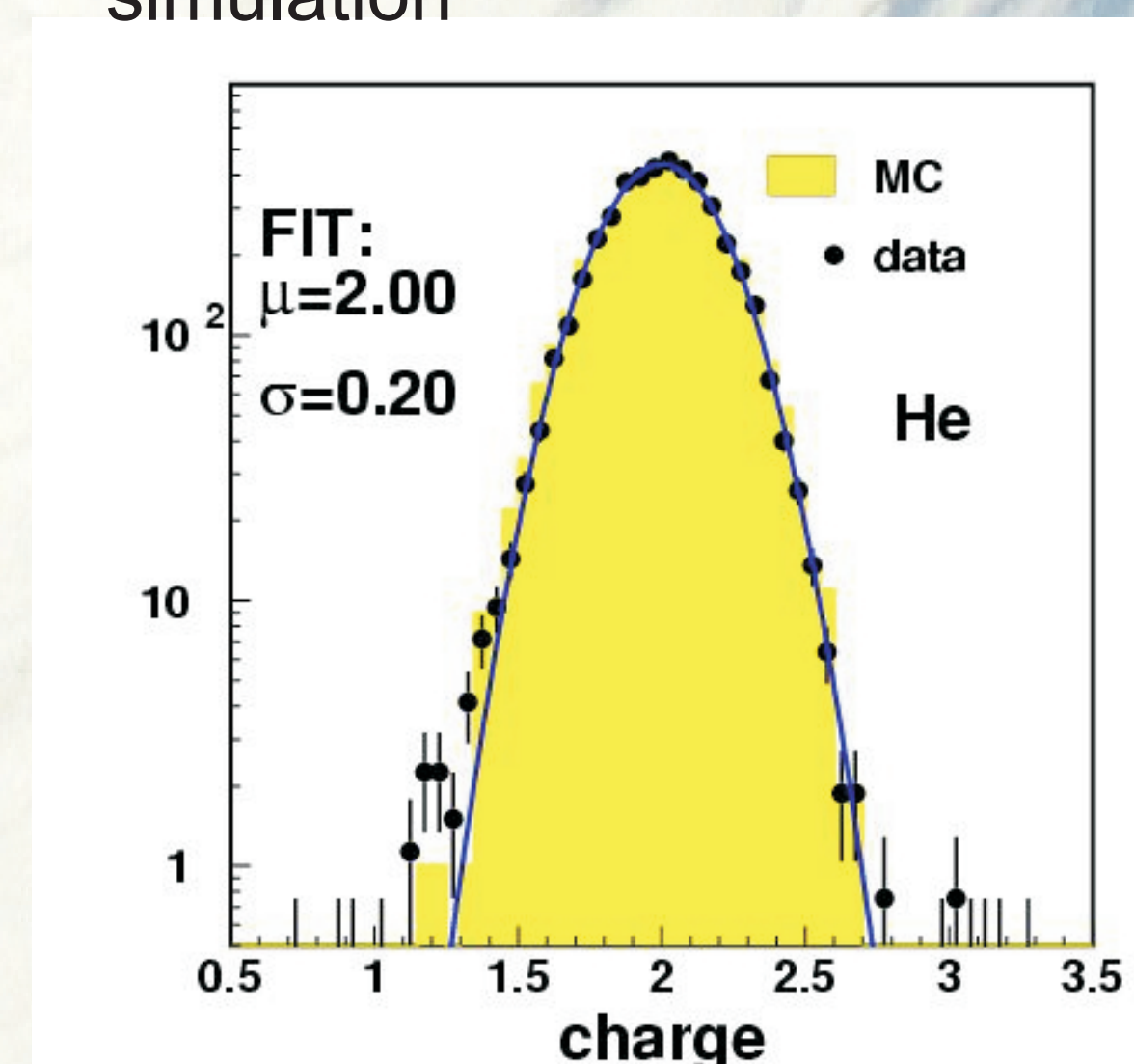

The charge resolution increases with Z as expected

